



AiM Infotech

# Water temperature sensor M10 thermo resistor

Release 1.05

---



# 1

## Introduction

---

AiM devices can measure and sample water temperature using a sensor (thermo resistor) placed in the cooling system.

The sensor part number is: **X05TRM10A4512BPS**.

# 2

## Installation and connection

---

The thermo resistor must be placed in the cooling system/oil sump.

It is recommended to install the sensor far from heat and electromagnetic interference sources (like RPM cable or lap receiver cables).

With reference to the images below, to install the sensor use the optional M10 thread inline water fitting (part number **LAA54120R**) shown on the left:

- cut the water pipe
- connect the inline water fitting to the pipe fixing two metal wraps in the points highlighted in the draw below
- screw the thermo resistor in the hole as shown on the right.

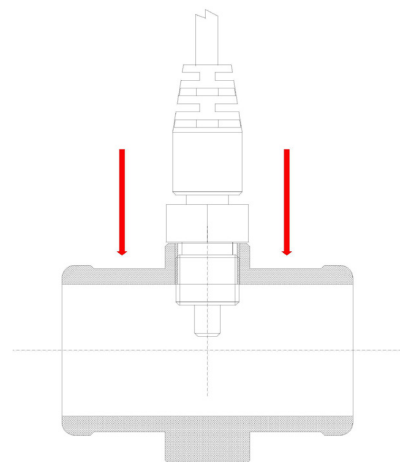

### 3

## Dimensions, pinout and technical characteristics

The draws here below show the sensor dimensions on the left and the inline water fitting dimensions on the right in millimetres [inches].

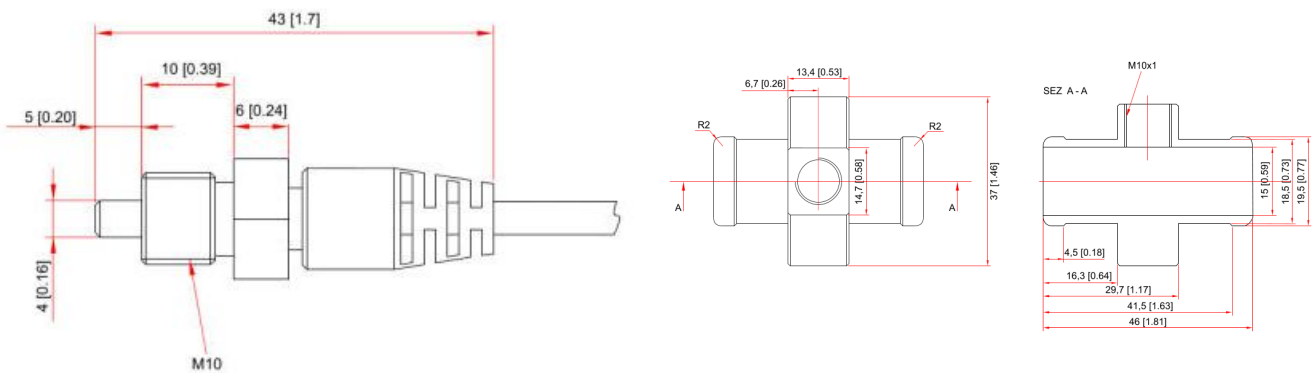

The sensor ends with a 4 pins male 719 Binder connector. Here below you see the connector pinout solder termination view as well as the connection table.

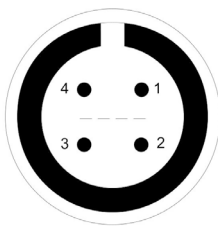

Pin	Function
1	Analog signal
2	GND
3	Not connected
4	+Vreference

The sensor technical characteristics are:

- Temperature working range: 0/150°C
- cable sensor length: 250 mm

## 4

### Extension cables

---

The sensor is sold with a 25 cm cable and standard lengths extension cables are available as optional.

**Mandatory** extension cable for connection with MyChron5 (metallic male Binder connector – 3 pins – plastic female Binder connector – 4 pins):

Product code: **V02PCB15BTR** (cable length: 1500mm)



**Mandatory** extension cable for connection with MyChron5 2T:

- **V02557110:** metallic male Binder connector – 7 pins; plastic female Binder connector – 4 pins + Mignon connector for thermocouples (cable length: 1500mm; image on the right)
- **V02557080:** metallic male Binder connector – 7 pins; 2 plastic female Binder connector – 4 pins (cable length: 1500mm)



**Mandatory** extension cable for connection with MyChron Expansion (metallic male Binder connector – 4 pins; plastic female Binder connector – 4 pins):

**Product code: V020455294** (cable length: 1500mm)

